

**DIN-191 and DIN-192 SERIES
CONVERTER BOXES
USERS MANUAL**

REVISED: 8/12/13

**DGH CORPORATION
PO BOX 5638
MANCHESTER, NH 03108**

**TELEPHONE: 603-622-0452
FAX: 603-622-0487
WEB: www.dghcorp.com**

The information in this publication has been carefully checked and is believed to be accurate; however, no responsibility is assumed for possible inaccuracies or omissions. Applications information in this manual is intended as suggestions for possible use of the products and not as explicit performance in a specific application. Specifications may be subject to change without notice.

WARRANTY

DGH warrants each DIN-191 and DIN-192 series module to be free from defects in materials and workmanship under normal conditions of use and service and will replace any component found to be defective, on its return to DGH, transportation charges prepaid within one year of its original purchase. DGH assumes no liability, expressed or implied, beyond its obligation to replace any component involved. Such warranty is in lieu of all other warranties expressed or implied.

RETURNS

When returning products for any reason, contact the factory and request a Return Authorization Number and shipping instructions. Write the Return Authorization Number on the outside of the shipping box. DGH strongly recommends that you insure the product for value prior to shipping. Items should not be returned collect, as they will not be accepted.

Shipping Address:

DGH Corporation
Hillhaven Industrial Park
146 Londonderry Turnpike
Hooksett, NH 03106

3 DIN-191 & DIN-192 USERS MANUAL

GENERAL DESCRIPTION

The DIN-191 and DIN-192 series converter boxes convert RS-232 communications signal levels to the correct electrical signals required by RS-485. The RS-485 communications standard is recommended when many modules, or other addressable devices, must be connected to a host computer over long distances. The DIN-191 and DIN-192 converters allow communications bus lengths up to 4,000 meters and baud rates up to 115K baud using one twisted pair of wires.

The RS-485 communications standard is half-duplex; therefore data can be transmitted in only one direction at a time. To determine the direction of data on the RS-485 bus, many products require external handshaking signals to control the bus direction when transmitting or receiving data. This technique often requires that host RS-232 software be written, or modified, to accurately control handshaking signals for proper system operation. The DIN-191 and DIN-192 automatically control the bus direction without external handshaking signals from the host. Therefore, host software written for RS-232 may be used without modification. RS-485 bus control is completely transparent to the user.

The DIN-192 is an RS-485 repeater. Repeaters are required to extend communications bus lengths or allow more than 32 RS-485 devices to be connected to a communications bus. A repeater simply re-amplifies, or boosts, existing RS-485 signals transmitted over long distances.

The DIN-191 and DIN-192 are each isolated between the RS-232 port and/or RS-485 ports and require a regulated +5Vdc power supply.

SPECIFICATIONS

Max common mode voltage: 500Vrms, 60s duration.
 Baud rates: 300, 600, 1200, 2400, 4800, 9600, 19200, 38400, 57600, 115200 (Dip -switch selectable).
 Temperature range (operating & storage): -25 to +70°C.
 Relative humidity: 0 - 95% noncondensing.
 Warranty: 12 months on workmanship and materials.

Power Specifications

Power requirements: Regulated +5Vdc.
 Power consumption: 1.0W Max (RS-485 driver on).

MECHANICALS AND DIMENSIONS

Case: ABS case with screw terminal barrier plug (supplied).
 RS-485 Connectors: Phoenix screw terminal barrier plug (supplied).
 Replace with Phoenix MSTB 2.5/4 ST 5.08 or equivalent.
 Warranty: 12 months on workmanship and materials.

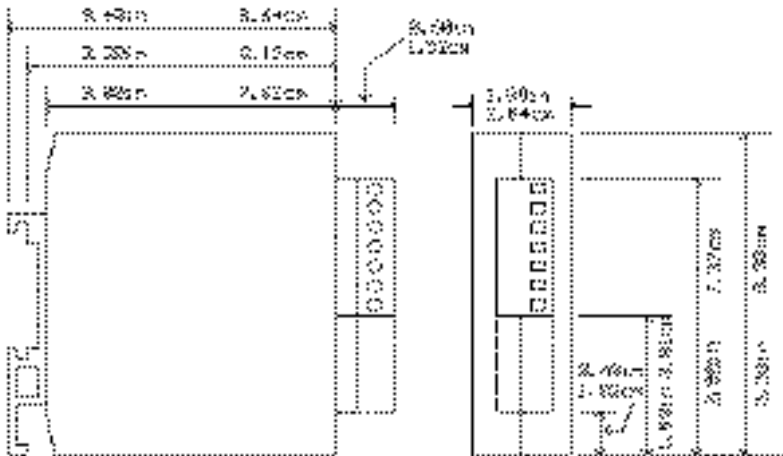

DIN-191 CONNECTORS

The DIN-191 contains two connectors: a four-pin screw terminal plug and a female DB-9 RS-232 connector.

The four -pin screw terminal plug pin designations are located on the label of each module. The screw terminals will accept up to #14 gauge wire (AWG). This connector is used for +5.0Vdc regulated power supply input and the RS-485 data lines.

5 DIN-191 & DIN-192 USERS MANUAL

The DIN-191 female RS-232 connector utilizes five connections:

Transmit	pin 2
Receive	pin 3.
Ground	pin 5.
Data Set Ready (DSR)	pin 6
Clear To Send (CTS)	pin 8

Both the Data Set Ready (DSR) input pin #6 and Clear To Send (CTS) input pin #8 are internally biased to their active state thru a 330 Ω resistor to +5Vdc.

To easily connect to any host PC computer, a straight thru RS-232 cable can be used. The RS-232 input Ground and signals are isolated by up to 500VRMS from the power supply ground. Cable CA-1 is a male-to-male DB-9 communications cable available for purchase from us.

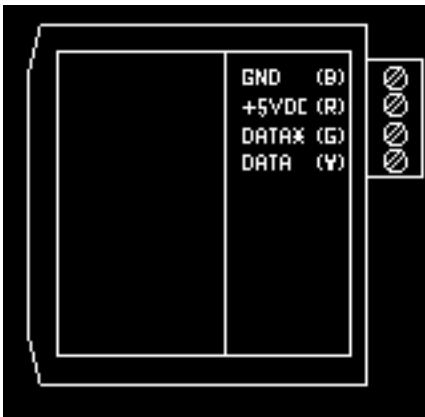

Figure 1A Connections for DIN-191.

An RS-485 repeater is necessary to extend the length of an RS-485 network, or connect more than 32 RS-485 devices on an RS-485 network.

The DIN-192 repeater contains a seven-pin screw terminal plug. The pin designations are located on the label of each module. The screw terminals will accept up to #14 gauge wire (AWG). This connector is used for +5.0Vdc regulated power supply input and both pairs of RS-485 data lines. The isolated RS-485 input data lines are clearly marked and their ground reference is isolated by up to 500VRMS from the power supply ground. The isolated RS-485 input data lines should be attached to the end of an existing RS-485 network. The serial data received on the

isolated RS-485 input data lines will be re-amplified and retransmitted on the RS-485 OUT data lines.

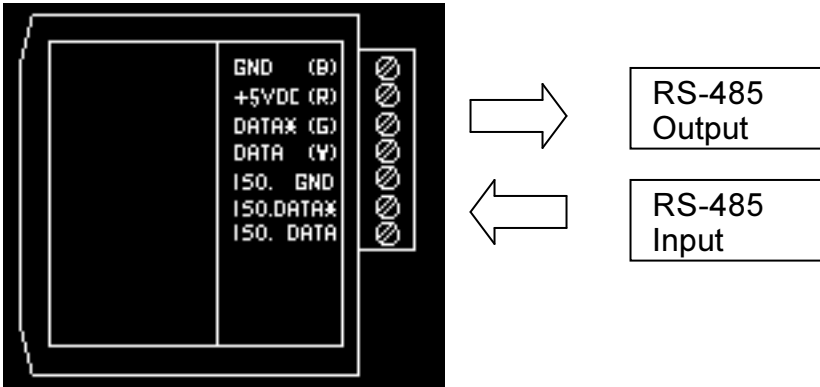

Figure 1B Connections for DIN-192.

BAUD RATE

The DIN-191 and DIN-192 series converters contain a 10-position DIP switch located on the bottom of each unit. The DIP switch is used to select the correct communications baud rate and must be set to the same value as the devices connected to the RS-485 data lines. Each position on the DIP switch is labeled from 1 to 10. Switch position 1 selects 300 baud. Switch positions 2 thru 9 select standard baud rates from 600 to 57.6K respectively. Switch position 10 selects 115.2K baud rate. Only one baud rate switch may be turned on (up position) at one time for proper operation.

RS-485 TERMINATIONS

The proper termination techniques for any RS-485 system require two biasing resistors and two termination resistors. The 1k Ω biasing resistors are connected from the DATA line to +5Vdc and from the DATA* line to ground. The biasing resistors are normally positioned at the HOST end of the cable. The RS-485 standard also requires two resistors across the data lines for proper termination. Two 220 Ω resistors should be connected between the DATA and DATA* lines. The resistors should be placed at each end of the RS-485 cable. Please refer to Figure 2 for a typical RS-485 system application.

The DIN-191 and DIN-192 each contain the biasing and termination resistors necessary to interface any equipment on an RS-485 network. These resistors are jumper-selectable making it easier to interface the DIN-191 and DIN-192 to other pieces of equipment that may or may not contain the biasing and/or termination resistors.

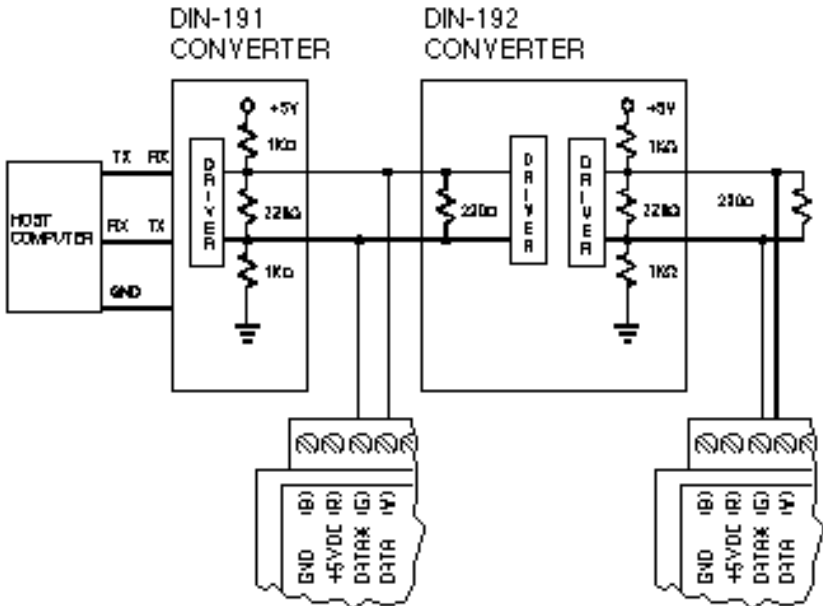

Figure 2. RS-485 biasing & termination resistors.

RS-485 TERMINATION & BIASING SETTINGS

Proper termination and biasing of any RS-485 based system can be performed by properly enabling the correct resistors inside each DIN-191 or DIN-192. Figures 3.0 and 4.0 show the location of the jumpers on the printed circuit board. The jumpers are shown in their factory set locations to enable the selected resistors. Insert or remove the jumpers as required to properly terminate any RS-485 system.

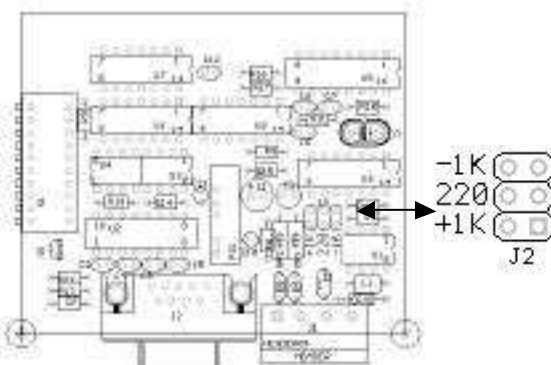

Figure 3. DIN-191 jumper locations.

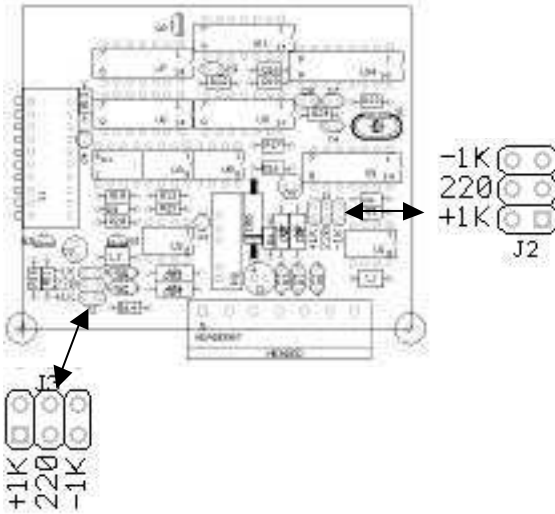

FIGURE 4. DIN-192 jumper locations.

FACTORY RS-485 TERMINATION SETTINGS

Each DIN-191 and DIN-192 contains internal pin strips for enabling the internal termination and biasing resistors. Each pc board is clearly marked with the jumper designators adjacent to each row of pins. The jumper designators are +1K, 220 and -1K. To enable any resistor, place a jumper over the pins next to the required designator. The factory switch and jumper settings are outlined below.

DIN-191:

Baud Rate: 300 baud switch up.

Biasing Resistors: +1K, -1K jumpers installed.

Termination Resistor: 220 jumper installed.

DIN-192:

Baud Rate: 300 baud switch up.

RS-485 (J3): Biasing Resistors: +1K, -1K jumpers installed.

Termination Resistor: 220 jumper installed.

Isolated RS-485 (J2): Biasing Resistors: +1K, -1K jumpers installed.

Termination Resistor: 220 jumper not installed.